

# Dust Extractor DS 6



# Powerful Dust Extractors for all Areas

Dust extractors in production processes protected against dust explosions (B1) all have one aim: to ensure a smooth running, dust-free production process.

Our systems are most suitable for extracting air-born dust DIRECTLY where it is generated, or from the production machine. Their wide range of performance means that they are suitable for almost all applications, both at a single point and as a central solution.

All dust extractors are fitted with large category C filters, which guarantee a long useful life.

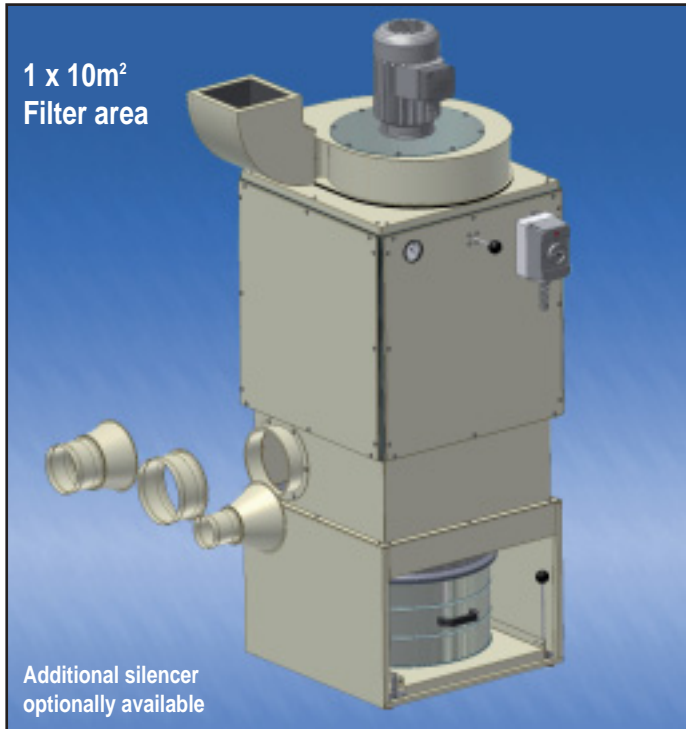

	DS 63000	DS 64000	DS 64400	DS 65600
Housing	Sheet steel	Sheet steel	Sheet steel	Sheet steel
*1) Length (mm)	approx. 692	approx. 692	approx. 692	approx. 692
*1) Width (mm)	approx. 712	approx. 712	approx. 712	approx. 712
Height (mm)	approx. 1.895/ 2.495	approx. 1.920/ 2.520	approx. 2.570	approx. 2.570
Engine Power (kW)	1,5	2,2	3,0	4,0
Voltage (Volt)	400	400	400	400
Vacuum (Pa)	2.300	2.600	3.000	3.400
*2) Air flow (m³/h)	2.600	3.600	4.000	5.200
*3) Air flow (m³/h)	3.000	4.000	4.400	5.600
Filterarea (m²)	10/20	10/20	20	20
Protection Class	IP 55	IP 55	IP 55	IP 55
*4) Sound Pressure (dB(A))	75	76	77	78
Suction Point (mm)	200	200	200	200
Capacity (ltr.)	55	55	55	55

\*1) not including the connector and vent

\*2) measured at the ventilator

\*3) measured with 3m hose, 200mm Ø

\*4) without silencer