

# Inductive motor vacuums

DS 2410

DS 2420

DS 2520

DS 2720



# High capacity vacuums

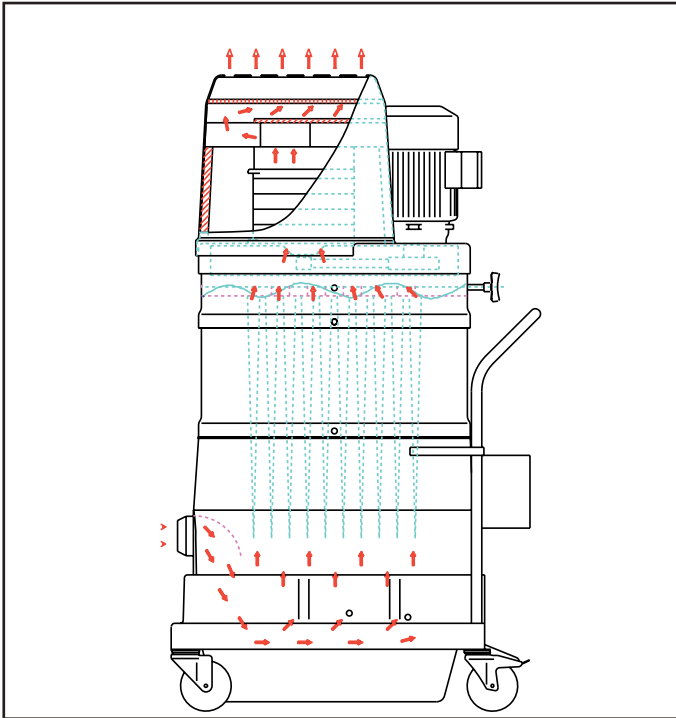

Foot lever actuated dust pan

- Composite housing, dent and corrosion resistant
- Modular housing construction, easily upgraded
- Compact design  
L 36" x W 28" x H 49,5"
- Inclusive sound suppression system
- Designed for continuous duty
- HEPA filters available

	DS 2410	DS 2420	DS 2520	DS 2720
Motor (kW) / (H.P.)	4,0	4,0	5,5	7,5
Voltage (Volt)	400	400	400	400
Vacuum (mmWC) / (CFM)	1.900	1.700	2.300	2.100
*1 Volume (m <sup>3</sup> /h)	410	540	650 / (770*2)	690 / (820*2)
Filter area (m <sup>2</sup> ) / (ft <sup>2</sup> )	4,5	4,5	4,5	4,5
Filter loading factor (m <sup>3</sup> .m <sup>-2</sup> .h <sup>-1</sup> )	91	120	144 / (171*2)	153 / (182*2)
Weight (kg)	94	102	127	133
Noise factor (dB(A))	72	74	75	77

\*1) Air volume measured with 3 meter hose and coated filter, TÜV certified.

\*2) Hose, Ø 100 mm diameter.

- Available in accordance with EN 60335-2-69 as industrial vacuum cleaner and dust extractor/industrial vacuum in dust categories L, M and H
- Available in accordance with ATEX 100a as dust explosion protection in dust categories M and H
- Available in accordance with ATEX 100a as gas explosion protection in dust categories L, M and H